

SPANN-BOX® size 0

Not only correct lubrication and wheel alignment, but also chain re-tensioning to compensate for elongation is of crucial importance for a satisfactory life cycle of a chain drive.

Apart from chain tension wheels, our chain tensioners SPANN-BOY® and SPANN-BOX® offer perfect solutions. Due to different sizes and profiles they cover almost all application areas.

For controlling purposes SPANN-BOY® and SPANN-BOX® can be fitted with limit or proximity switches.

We can also supply SPANN-BOY® and SPANN-BOX® with casings or springs made of stainless steel.



SPANN-BOY®



SPANN-BOX® size 1
with deflecting profile

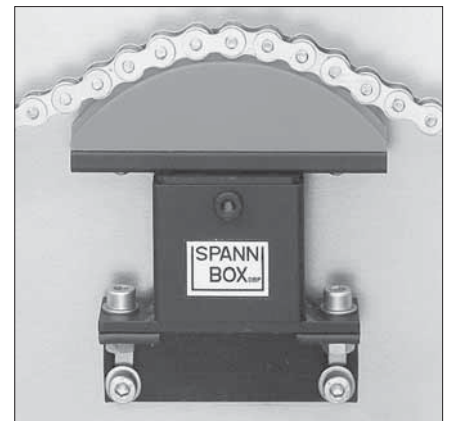

SPANN-BOX® size 1
with arch profile



Typ-KL

SPANN-BOX® size 1
with sprocket

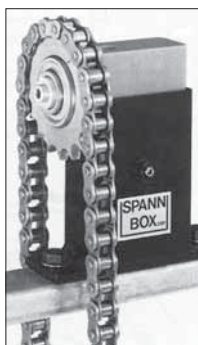

Typ-KS

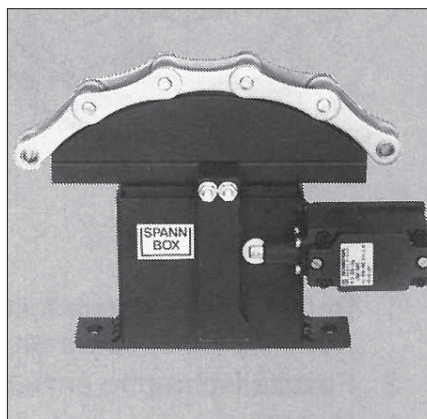

SPANN-BOX® size 1
with arch profile and limit switch



SPANN-BOX® size 2
with block profile



Chain No.	Pitch mm	Arch profile				Semicircle profile				Deflecting profile				Block profile				Sprocket															
		Size				SPANN-BOY®				Size				SPANN-BOY®				Size				SPANN-BOY®											
		0	30	1	2					0	30	1	2					0	30	1	2					0	30	1	2				
not mentioned chains with width up to 15 mm						X				X																							
455	9,525			X						X	X					X																	
D 455	9,525		X	X			X			X	X					X																	
T 455	9,525		X	X			X			X	X					X																	
462	12,7		X	X			X	X			X					X												X				X	
D 462	12,7		X	X	X		X	X	X		X	X				X	X																
T 462	12,7		X	X	X		X	X	X		X	X				X	X																
501	15,875		X	X			X			X	X					X												X				X	
D 501	15,875		X	X	X		X			X	X					X	X																
T 501	15,875			X	X						X					X																	
513	19,05		X	X	X		X			X	X					X	X											X				X	
D 513	19,05		X	X	X		X			X	X					X	X																
T 513	19,05			X	X						X					X																	
548	25,4		X	X	X						X					X	X																
D 548	25,4			X	X																X												
T 548	25,4				X																X												
563	31,75			X	X								X																				
D 563	31,75				X																X												
T 563	31,75				X																X												
596	38,1				X																X												
D 596	38,1				X																X												
T 596	38,1																				X												
613	44,45																				X												
D 613	44,45																				X												
T 613	44,45																				X												
652	50,8																				X												
D 652	50,8																				X												
T 652	50,8																				X												
671	63,5																				X												
D 671	63,5																				X												
T 671	63,5																				X												
679	76,2																				X												
D 679	76,2																				X												
T 679	76,2																				X												

Tension values and range of shift

Size	SPANN-BOY®		SPANN-BOX® size 0		SPANN-BOX® size 30 or 1		SPANN-BOX® size 2	
Range of shift	40 mm		40 mm		40 mm		60 mm	
Spring design	light	heavy	light	heavy	light	heavy	light	heavy
Tension force	N		N		N		N	
1 spring released	58 - 32	132 - 60	58 - 32	132 - 60	58 - 32	132 - 60	148 - 82	262 - 116
2 springs released	-	-	-	-	116 - 64	264 - 120	296 - 164	524 - 236
3 springs released	-	-	-	-	174 - 96	396 - 180	444 - 246	786 - 454

The chain weight should not be higher than the force of a spring already released by 50%.

The second and the third spring may be activated later if required.

Further combinations and profiles made to specification are also available.



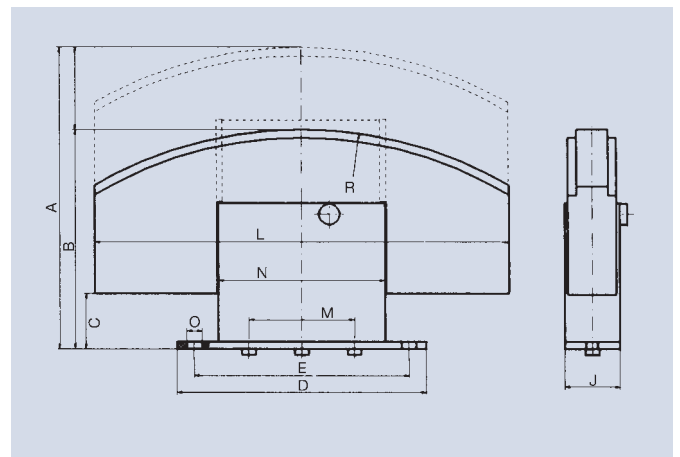
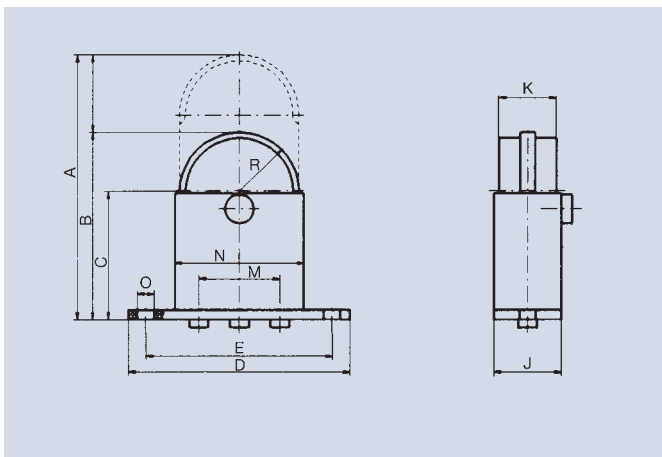
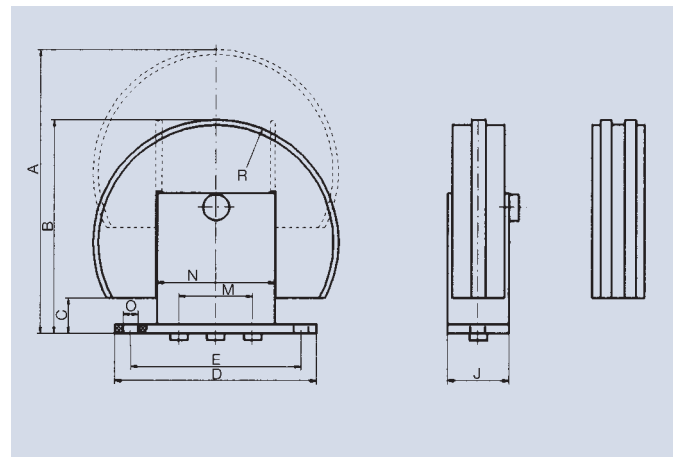
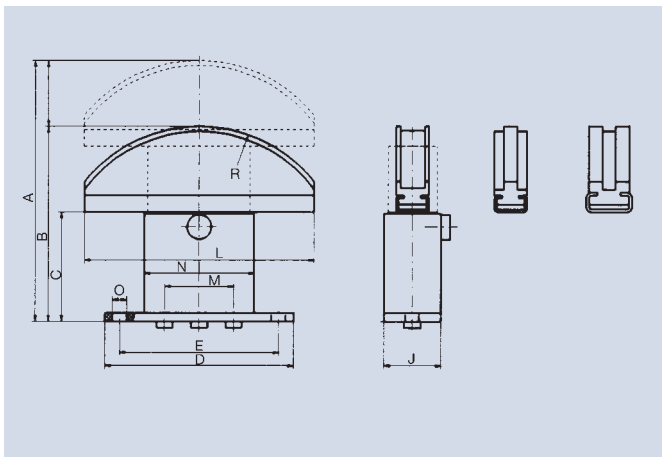
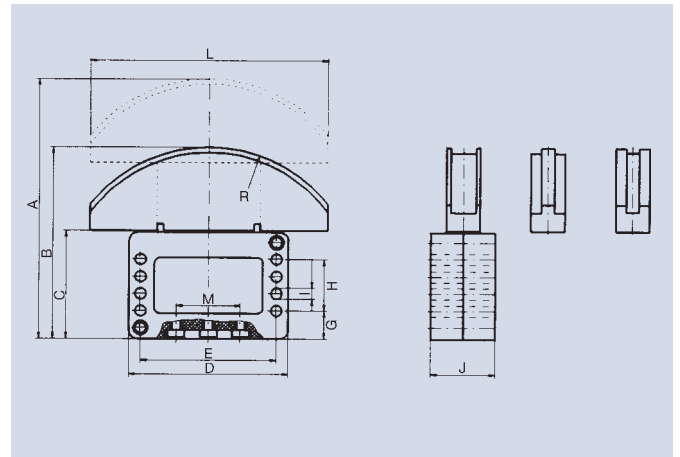
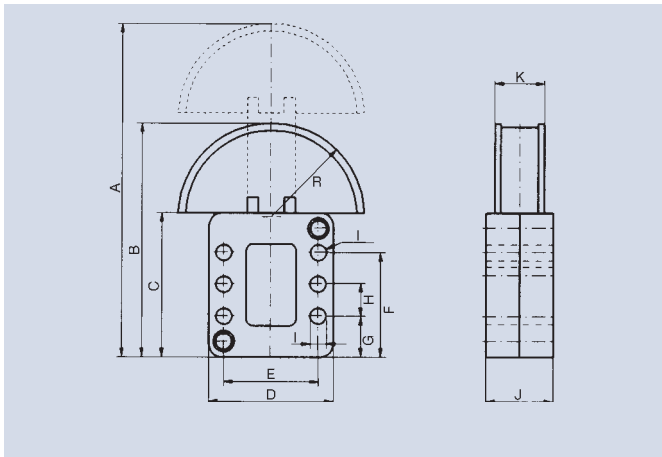

Dimensions	Ind.	A	B	C	D	E	F	G	H	I	J	K	L	M	N	O	R
Size 0		134	94	58	50	38	42	16,2	12,9	6,5	27	20	-	-	-	-	37,5
Size 30		152,5	112,5	63,5	94	80	-	16,5	30	6,5	38	-	140	38	-	-	90
Size 1, arch profile		158	118	66	115	97	-	-	-	-	35	-	140	42	67	8,5	90
Size 1, arch profile	*	173	133	81	115	97	-	-	-	-	40	-	140	42	67	8,5	90
Size 1, semicircle profile		137	97	66	115	97	-	-	-	-	35	30	-	42	67	8,5	31
Size 1, semicircle profile	*	152	112	81	115	97	-	-	-	-	40	30	-	42	67	8,5	31
Size 1, deflecting profile		162	122	20	115	97	-	-	-	-	35	-	-	42	67	8,5	70
Size 2, arch profile		209	149	86	180	155	-	-	-	-	40	-	200	76	120	11	150
Size 2, arch profile	*	229	169	106	180	155	-	-	-	-	40	-	200	76	120	11	150
Size 2, semicircle profile		203	143	86	180	155	-	-	-	-	40	35	-	76	120	11	57
Size 2, semicircle profile	*	223	163	106	180	155	-	-	-	-	40	35	-	76	120	11	57
Size 2, deflecting profile		225	165	40	180	155	-	-	-	-	40	-	-	76	120	11	100
Size 2, block profile		218	158	40	180	155	-	-	-	-	40	-	300	76	120	11	300

* long casing

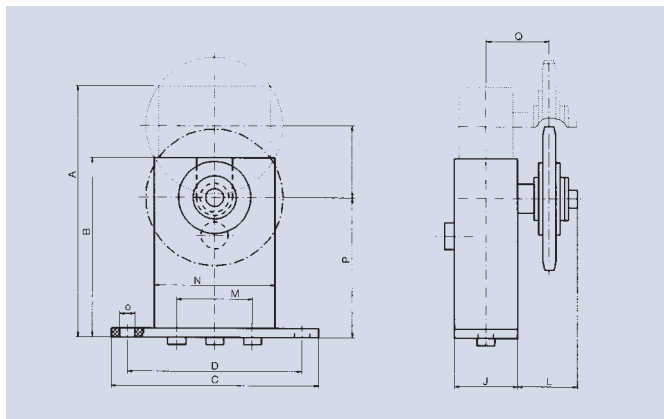

SPANN-BOX® size 1 with sprocket type KL

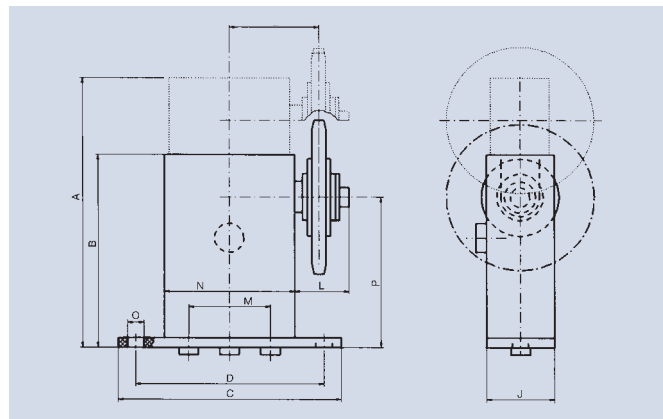

SPANN-BOX® size 1 with sprocket type KS

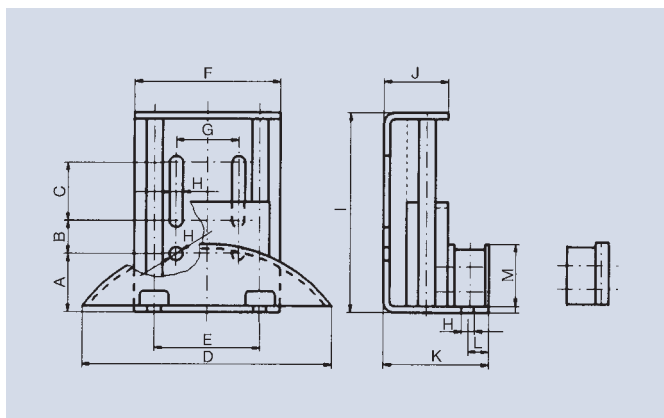

SPANN-BOY® with arch profile

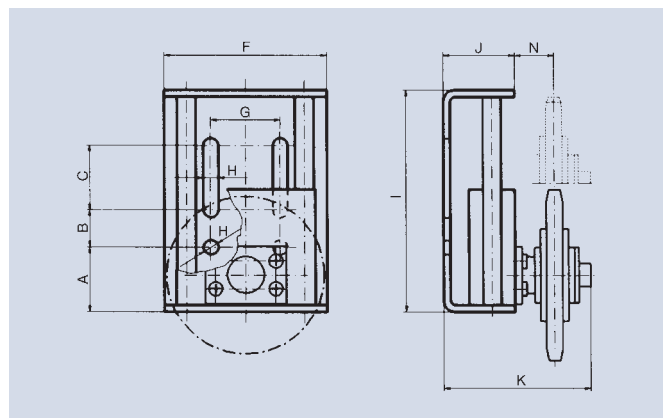

SPANN-BOY® with sprocket

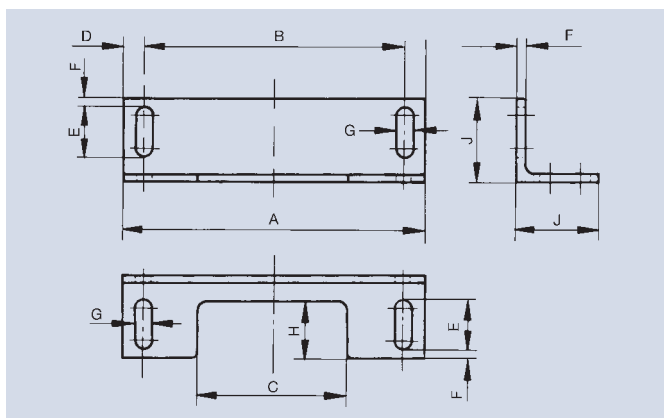

Mounting bracket for SPANN-BOX® size 1 and 2

Standard sprockets

Chain No.	Number of teeth			
	20	21	23	
455	20	21	23	
462	16	17	18	
501	14	15	16	17
513	13	15	16	17

Dimensions	A	B	C	D	E	F	G	H	I	J	K	L	M	N	O	P	Q
SPANN-BOX® size 1 (type KL)	140	100	115	97	-	-	-	-	-	35	8,5	35 max.	42	67	8,5	78	35
SPANN-BOX® size 1 (type KS)	140	100	115	97	-	-	-	-	-	35	8,5	30 max.	42	67	8,5	78	46
Bracket size 1	115	97	60	9	25	5	8,5	30	-	45	-	-	-	-	-	-	-
Bracket size 2	180	155	90	12,5	30	5	11	35	-	50	-	-	-	-	-	-	-
SPANN-BOY® (arch profile)	28	16	28	120	50,8	70	30	6,4	96	31	51	10	30	-	-	-	-
SPANN-BOY® (with sprocket)	28	16	28	-	-	70	30	6,4	96	31	66 max.	-	-	17	-	-	-

SPANN-BOX® and mounting brackets made of stainless steel grade 1.4301 on request (Please note: different sizes!)