

DISC BRAKE SYSTEM – COMPACT 95

SPRING APPLIED, HYDRAULIC PRESSURE RELEASED DISC BRAKE
WITH SUPPORT AND HYDRAULIC POWER PACK

Dellner Compact 95 is a complete, ready to use, safety brake system which includes disc brake, support and hydraulic power pack (HPP) with one interface.

The system is very compact, light weight, durable and suitable for outdoor / dirty environments (IP65).

The HPP is capable to actuate a second brake through a hose (twin mounting). It is also possible to separate the HPP, and mount it remote from the support. (In this case hydraulic tubing is not included).

The Compact 95 systems are designed for 12 mm thick brake discs. When used with thicker discs the systems can be supplied with spacers.

To maintain full brake torque the brakes should be adjusted when below mentioned maximum air gap value is exceeded. An extension of the brake piston through the adjustment nut gives an easy visual way to tell when adjustment is needed. As standard the Compact 95 systems are delivered with Dellner “Easy adjustment” feature.

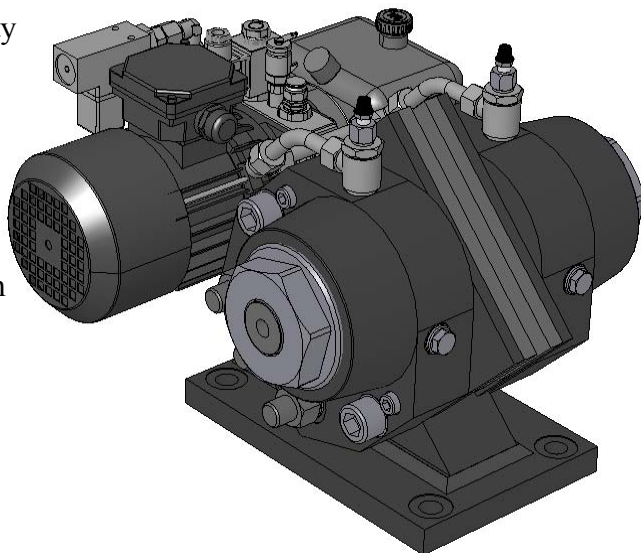

Compact model	Tangential braking force F [N] ¹⁾		Releasing pressure [bar] ⁴⁾	Air gap between brake disc and lining [mm]		Estimated life of disc spring pack [no. of strokes]		Friction area per brake [cm ²]	Weight [kg]
	max. ²⁾	min. ³⁾		min. ⁵⁾	max. ⁶⁾	min. ⁷⁾	max. ⁸⁾		
95-10	12600	10700	45			>2x10 ⁶	>2x10 ⁶	402	75
95-14	17800	14300	65			>2x10 ⁶	>2x10 ⁶		
95-18	24000	18200	90	2x1,0	2x2,5	>2x10 ⁶	>2x10 ⁶		
95-27	33500	27800	115			>6x10 ⁵	>1x10 ⁶		

- 1) Calculated with an average frictional coefficient $\mu=0,42$. Consideration has not been taken for external factors.
- 2) Braking force with correctly adjusted disc spring pack.
- 3) Braking force with maximum recommended air gap before adjustment is needed.
- 4) Pressure to fully release brake.
- 5) Air gap for correctly adjusted brake.
- 6) Maximum recommended air gap before adjustment is needed.
- 7) Valid for minimum spring pack compression.
- 8) Valid for maximum spring pack compression.

Options

- ✚ Proximity or mechanical switches for indicating on/off, pad wear or “time to adjust”.
- ✚ HPP for remote vertical mounting
- ✚ Console for remote mounting of vertical or horizontal HPP
- ✚ Other voltages for motor and solenoids than standard.
- ✚ ATEX approval available (causes changed outer dimensions on HPP)
- ✚ Cover for HPP



Dimensions / Hydraulic Circuit

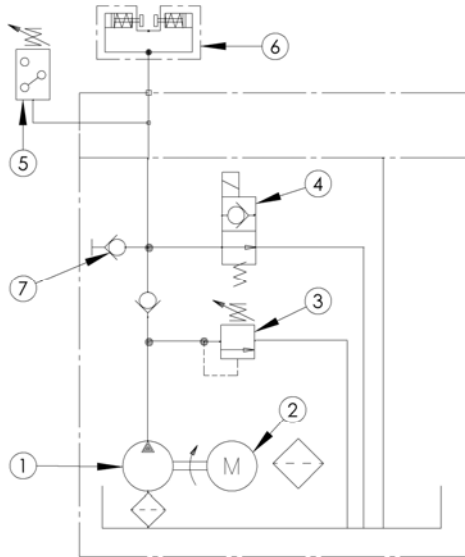
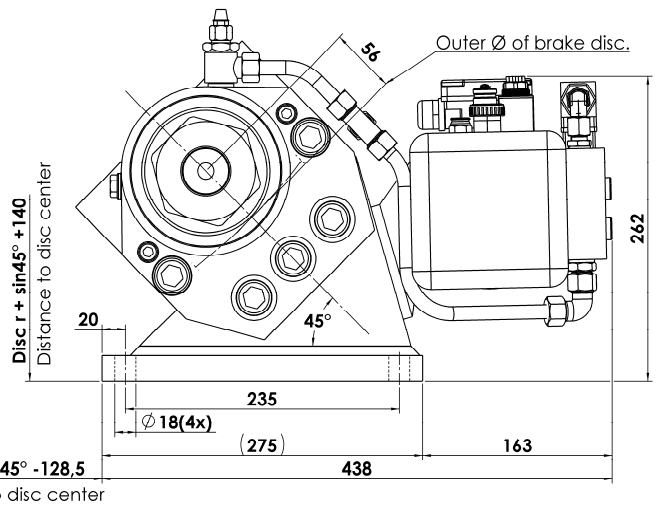
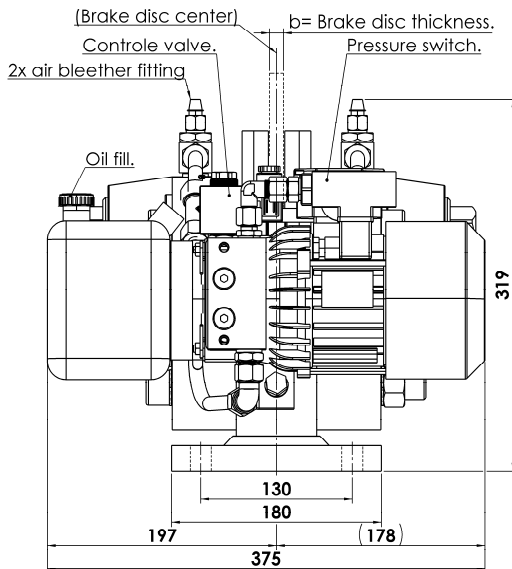

Detail	Description
1	Pump 1.4 l/min
2	Electric motor 230/400 V, 50 Hz, 0.37 kW
3	Pressure relief valve 150 bar
4	Control valve (solenoid valve) 24 VDC
5	Pressure switch (Set value 120 bar decreasing)
6	Caliper Disc Brake SKP 95
7	Test connector M16-1/4"

Torque table

The braking torque is calculated from the following formula:

$$M_{brake} = \frac{q \times F \times (D_s - H)}{2}$$

Compact model	Tangential braking force F [N] ¹⁾		Disc diameter D [mm]							
	max. ²⁾	min. ³⁾	ø400	ø450	ø500	ø600	ø700	ø800	ø900	ø1000
95-10		10700	1490	1760	2030	2560	3100	3630	4170	4700
	12600		1760	2070	2390	3024	3650	4280	4910	5540
95-14		14300	2000	2350	2710	3430	4140	4860	5570	6290
	17800		2490	2930	3380	4270	5160	6050	6940	7830
95-18		18200	2540	3000	3450	4360	5270	6180	7090	8000
	24000		3360	3960	4560	5760	6960	8160	9360	10560
95-27		27800	3890	4587	5280	6670	8060	9450	10840	12230
	33500		4690	5520	6360	8040	9710	11390	13060	14740

- 1) Calculated with an average frictional coefficient $\mu=0,42$. Consideration has not been taken for external factors.
- 2) Braking force with correctly adjusted disc spring pack.
- 3) Braking force with maximum recommended air gap before adjustment is needed.

Dellner Brakes AB
Skyfallsvägen 2
SE-791 77 FALUN
SWEDEN