

hydraulic connection G 1/2"

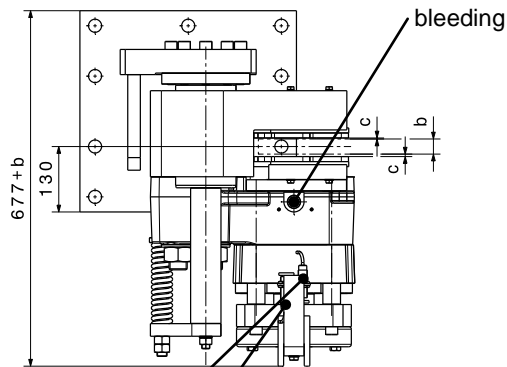

optional limit switch:
lining wear

optional limit switch:
brake open / close

Mounting Studs			
n	quantity		10
	size, grade		M24, 8.8
M _A	fastening torque	Nm	710 at μ=0,14
Linings			
	material		sinter
	friction coefficient *		0,4

*average friction coefficient with standard material combination and a circumferential speed up to 15 m/s

SHI-Type		231 FC	232 FC	
Clamping Force F_A				
F _A	with airgap c = 1 mm	kN	240	300
F _A	with airgap c = 1,5 mm	kN	225	270
Torque Calculation				
M _{Br}	braking torque Nm	2 x F _A x μ x (d/2-95)		
Hydraulic				
P _L	release pressure	bar	130	170
P _{max}	max. pressure	bar	175	205
V _{max}	volume at c= 1,5 mm	ltr	0,076	
Brake Discs				
b	disc thickness	mm	20 ≤ b ≤ 40	
d	disc-Ø	mm	900 ≤ d ≤ 2400	
d ₁	max. hub- / drum-Ø	mm	d - 440	
Dimensions				
L x W x H = 545 x (677+b) x 910 mm				
max. weight: 660 kg				

When ordering please advise: right hand version, as shown;
left hand version, mirror inverted!