

hydraulic connection G 1/2"

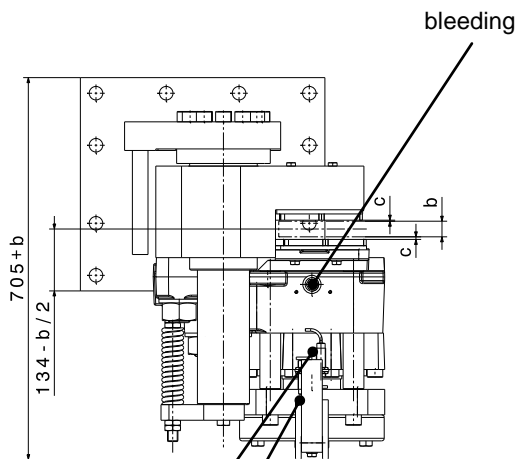

optional limit switch:  
lining wear

optional limit switch:  
brake open / close

Mounting Studs			
n	quantity		12
	size, grade		M24, 12.9
M <sub>A</sub>	fastening torque	Nm	1200 at μ=0,14
Linings			
	material		sinter
	friction coefficient *		0,4

\*average friction coefficient with standard material combination and a circumferential speed up to 15 m/s

SHI-Type		251 FC	252 FC	
<b>Clamping Force F<sub>A</sub></b>				
F <sub>A</sub>	with airgap c = 1 mm	kN	302	400
F <sub>A</sub>	with airgap c = 1,5 mm	kN	270	360
<b>Torque Calculation</b>				
M <sub>Br</sub>	braking torque Nm	2 x F <sub>A</sub> x μ x (d/2-100)		
<b>Hydraulic</b>				
P <sub>L</sub>	release pressure	bar	105	140
P <sub>max</sub>	max. pressure	bar	205	205
V <sub>max</sub>	volume at c= 1,5 mm	ltr	0,106	
<b>Brake Discs</b>				
b	disc thickness	mm	20 ≤ b ≤ 40	
d	disc-Ø	mm	1300 ≤ d ≤ 2200	
d <sub>1</sub>	max. hub- / drum-Ø	mm	d-490	
<b>Dimensions</b>				
L x B x H = 585 x (705+b) x 930 mm				
max. weight: 810 kg				

When ordering please advise: right hand version, as shown;  
left hand version, mirror inverted!