

limit switch „released“
directional limit switch „right“
directional limit switch „left“
12mm nominal distance brake „released“

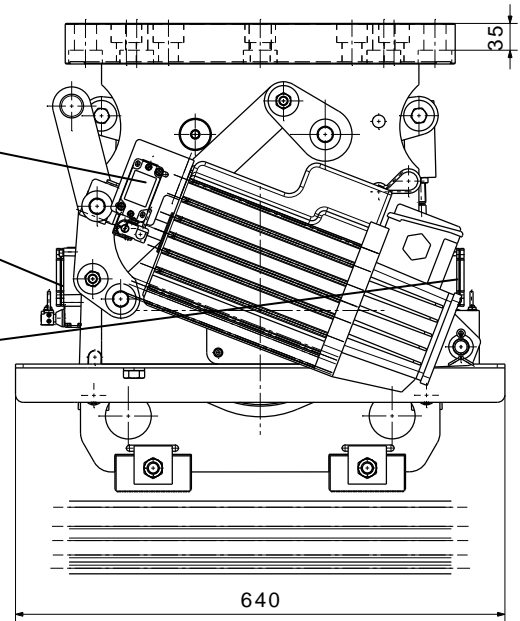

8 bores Ø29 for cylinder-head screws
DIN912-M27x80-10.9
MA= 1250Nm, μ 0,14

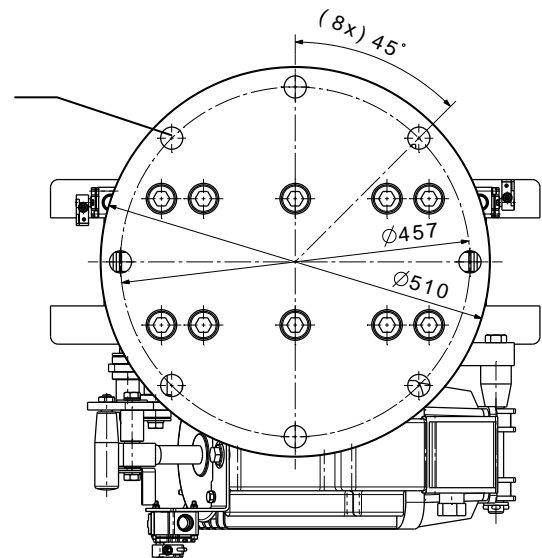
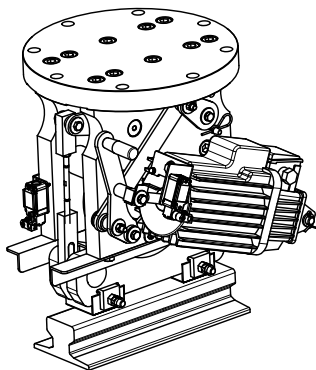

Technical Data:

- Bi-directionally acting, static storm brake for gantry travel.
- **Max. holding force $F_H = 225 \text{ KN}$.** It is generated by a wedge clamped between clamp wheel and crane rail.
- Released by Eldro thruster.
- Thruster with lowering valve and c-spring.
- With manual release lockable in released position.
- Field replaceable brake shoes.
- Brake shoes hardened and on the area of support it is carried out with sprockets.
- Limit switch for brake „released“.
- Limit switch for directional indication.
- Weight approx. 400kg.

Information:

- The crane can travel between 50mm and 100mm before the rail brake is engaged.
- Nominal gap between rail and released brake shoe is 12mm.
- Max. permissible deviation of rail height is +/- 6mm.
- The rail brake is designed for installation under gantry travel cross-beam.