

FLEXIBLE COUPLINGS

ORPEX®



ORPEX®

Orpex® couplings are used as compensation couplings everywhere where an absolutely reliable torque transfer is required. Orpex® couplings cover with their types a wide range of uses. With a total of 26 sizes, couplings are available for torques from 200 to 1,300,000 Nm. The coupling halves of the type WN consist of grey cast iron. With the WS type of steel it is possible to use the coupling with high speeds. With the convex elastic elements which can be moved in the holes - the buffers - it is possible to compensate for the shaft offsets in angular, radial and axial direction. Orpex® couplings damp torque impacts and offer the possibility of shifting critical speeds. Orpex® couplings are fail-safe up to the fracture moment of the metal parts, which is a multiple of the permissible impact moment, and thus offers the greatest possible operational safety. Orpex® couplings can be used for both directions of rotation and are also suitable for reversing operation. The buffers can be expected to have a long life with correct design of the coupling and correct alignment of the assembly. Orpex® couplings can also be adapted in many ways to special requirement profiles.



TYPE

- > WN
- > WS

A large number of applications already created and tried are available for this. Our Projects Department would be pleased to advise you. Orpex® couplings have proven themselves over decades in all areas of mechanical engineering, especially in the case of heavy-duty drives, as an absolutely reliable and practically maintenance-free machine element.

FUNCTIONING

The positive torque transfer is achieved by means of elastic elements subjected exclusively to pressure which then deform elastically under compression. The progressive spring characteristic and the excellent damping properties of the buffers counteract the dangerous build-up of any rotary vibrations that occur.

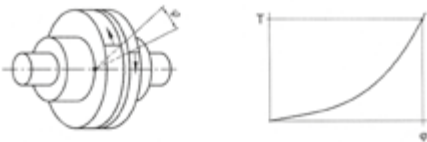

Torsion spring strips and torsional angles

The optimised round convex form of the buffers favours the compensatory function where angular or radial offsets are present and minimises restoring forces. The ground bolts are fastened with no play by means of a conical seat. This effectively prevents any possible widening of the locating hole and the development of frictional corrosion. The convex buffers of the Orpex® couplings can be mounted by plugging in. It is possible to replace the bolts and buffers without any axial displacement of the motor or the machines. Uncoupled machines can be dismantled radially. The buffers can be used at ambient temperatures of -30°C to $+80^{\circ}\text{C}$. They are resistant by electrical conduction against oil and many other media.

TECHNICAL DETAILS

- Perfect transfer of the torque and trouble-free functioning are only guaranteed when original Orpex® buffers are used.
- The arrangement of the coupling parts of the types WN and WS on the shaft ends to be connected is discretionary. Both horizontal and vertical installation is possible.
- Orpex® couplings are normally fitted with a feather key groove according to DIN 6885 part 1 and set screw. Design with wedge groove according to DIN 6886, tightening from inside of hub, is possible. Care must be taken here to ensure that the maximum allowable holes only amount to 60% of the maximum allowable holes with key feather groove according to DIN 6885 part 1.
- Rotating parts must be secured by the purchaser to prevent un-intentional contact. When products are supplied to other countries the safety regulations applying there must be observed.
- The shaft ends to be connected must be stored immediately in front of and behind the coupling.
- We are at your service for design to DIN 740 part 2 and for vibration calculations. Vibration calculations can also be ordered from Engineering Service.
- With respect to the installation and commissioning of Orpex® couplings the installation and operating instructions must be observed.



TYPE WN GREY CAST IRON

SIZE 105 TO 500

Size	$D_{1/2}^{(1)}$ min. mm	$D_1^{(1)}$ max. mm	$D_2^{(1)}$ max. mm	d_a mm	d_1 mm	d_2 mm	l mm	P mm	S mm	W mm	u mm
105	-	32	38	105	53	59	45	30	2...4	12	13
125	-	40	48	125	65	68	50	35	2...4	15	16
144	-	45	55	144	76	84	55	35	2...4	15	16
162	-	50	60	162	85	92	60	40	2...5	18	20
178	-	60	70	178	102	108	70	40	2...5	18	20
198	-	70	80	198	120	128	80	40	2...5	18	20
228	-	80	90	228	129	140	90	50	2...5	24	26
252	38	90	100	252	150	160	100	50	2...5	24	26
285	48	100	110	285	164	175	110	60	3...6	30	32
320	55	110	120	320	180	192	125	60	3...6	30	32
360	65	120	130	360	200	210	140	75	3...6	42	42
400	75	140	140	400	230	230	160	75	3...6	-	42
450	85	160	160	450	260	260	180	90	4...7	-	52
500	95	180	180	500	290	290	200	90	4...7	-	52

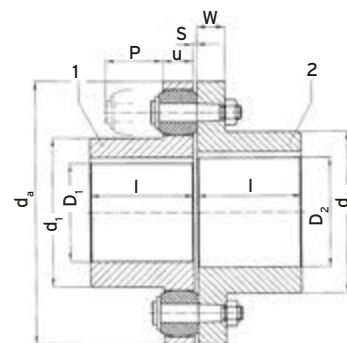

> Size 105-360

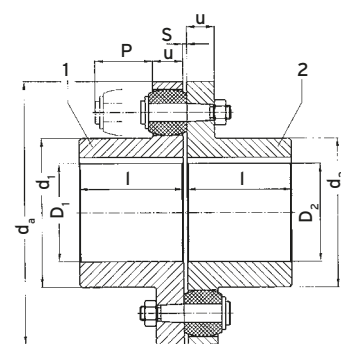

> Size 400

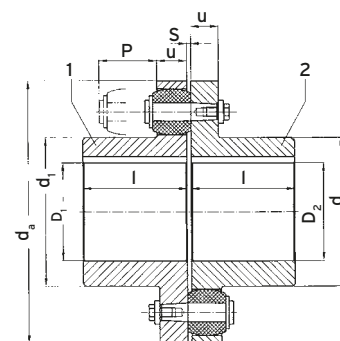

> Size 450-500

Size	Nominal torque ²⁾	Max. rotation speed rpm	Moments of inertia ³⁾ kgm ²		Weight ³⁾ kg	
	T_{KN} Nm		part 1	part 2	part 1	part 2
105	200	5000	0.001	0.001	0.96	1.2
125	350	5000	0.003	0.003	1.9	1.9
144	500	4900	0.004	0.006	2.2	3.1
162	750	4300	0.007	0.013	3.2	4.6
178	950	3800	0.014	0.022	4.8	6.7
198	1300	3400	0.023	0.031	7	8.6
228	2200	3000	0.04	0.074	9.1	14
252	2750	2700	0.07	0.12	13	18.5
285	4300	2400	0.13	0.22	19	26.5
320	5500	2100	0.23	0.31	27	35
360	7800	1900	0.42	0.71	37	52
400	12500	1700	0.89	0.89	60	60
450	18500	1500	1.7	1.7	89	89
500	25000	1350	2.8	2.8	115	115

- 1) Drill holes H7 with keyway in accordance with DIN 6885/1; tolerance zone JS9 and set screws on the keyway
- 2) Torques for shaft fit with keyway
- 3) The details of weight and moments of inertia apply for medium holes D_1 , D_2 .

TYPE WS STEEL

SIZE 105 TO 500

Size	$D_{1/2}^{(1)}$	$D_1^{(1)}$	$D_2^{(1)}$	d_a	d_1	d_2	l	P	S	W	u
	min. mm	max. mm	max. mm	mm	mm	mm	mm	mm	mm	mm	mm
105	-	32	38	105	53	59	45	30	2...4	12	13
125	-	40	48	125	65	68	50	35	2...4	15	16
144	-	50	60	144	76	84	55	35	2...4	15	16
162	-	55	65	162	85	92	60	40	2...5	18	20
178	-	70	75	178	102	108	70	40	2...5	18	20
198	-	80	85	198	120	128	80	40	2...5	18	20
228	-	85	95	228	129	140	90	50	2...5	24	26
252	38	100	110	252	150	160	100	50	2...5	24	26
285	48	110	120	285	164	175	110	60	3...6	30	32
320	55	125	130	320	180	192	125	60	3...6	30	32
360	65	135	140	360	200	210	140	75	3...6	42	42
400	75	150	150	400	230	230	160	75	3...6	-	42
450	85	170	170	450	260	260	180	90	4...7	-	52
500	95	190	190	500	290	290	200	90	4...7	-	52

Size	Nominal torque ²⁾	Max. rotation speed	Moments of inertia ³⁾		Weight ³⁾	
	T_{KN} Nm	rpm	kgm ²		kg	
			part 1	part 2	part 1	part 2
105	200	5000	0.001	0.001	0.96	1.2
125	350	5000	0.003	0.003	1.6	1.9
144	500	5000	0.004	0.006	2.2	3.1
162	750	5000	0.007	0.013	3.2	4.6
178	950	4900	0.014	0.022	4.8	6.7
198	1300	4600	0.023	0.031	7	8.6
228	2200	4400	0.04	0.074	9.1	14
252	2750	4200	0.07	0.12	13	18.5
285	4300	3900	0.13	0.22	19	26.5
320	5500	3500	0.24	0.33	27	35
360	7800	3100	0.42	0.71	37	52
400	12500	2800	0.95	0.95	63	63
450	18500	2500	1.8	1.8	93	93
500	25000	2200	2.9	2.9	125	125

1) Drill holes H7 with keyway in accordance with DIN 6885/1; tolerance zone JS9 and set screws on the keyway

2) Torques for shaft fit with keyway

3) The details of weight and moments of inertia apply for medium holes D_1 , D_2 .

SIZE 560 TO 2000

Size	$D_{1/2}$ ¹⁾				WN	WN	WS	WN	WN	WN	WN	WN
	WN min. mm	WN max. mm	WS min. mm	WS max. mm	d_a mm	$d_{1/2}$ mm	$d_{1/2}$ mm	l mm	v mm	P mm	S mm	u mm
560	100	140	100	165	560	250	250	220	70	120	4...8	68
	> 140	180	> 165	200		300	300					
	> 180	200	> 200	210		320	320					
630	100	140	100	165	630	250	250	240	80	120	4...8	68
	> 140	180	> 165	200		300	300					
	> 180	200	> 200	235		355	355					
710	110	160	110	190	710	290	290	260	80	140	5...9	80
	> 160	200	> 190	220		330	330					
	> 200	240	> 220	250		385	385					
800	125	180	125	210	800	320	320	290	90	140	5...9	80
	> 180	220	> 210	240		360	360					
	> 220	260	> 240	280		420	420					
900	140	220	> 210	240	900	360	360	320	100	160	5...10	90
	> 220	260	> 240	280		425	425					
	> 260	290	> 280	310		465	465					
1000	150	240	> 230	260	1000	395	395	350	110	160	5...10	90
	> 240	280	> 260	300		460	460					
	> 280	320	> 300	340		515	515					
1120	160	200	160	270	1120	360	360	380	120	180	6...11	100
	> 200	250	> 240	300		410	410					
	> 250	300	> 270	360		495	495					
1250	180	230	180	270	1250	410	410	420	130	180	6...11	100
	> 230	280	> 270	300		460	460					
	> 280	330	> 300	360		540	540					
1400	200	260	200	310	1400	465	465	480	145	210	6...12	120
	> 260	320	> 310	350		525	525					
	> 320	380	> 350	410		620	620					
1600	260	320	260	370	1600	565	565	540	165	210	6...12	120
	> 320	380	> 370	410		625	625					
	> 380	440	> 410	480		720	720					
1800	320	380	320	440	1800	660	660	600	185	240	8...16	140
	> 380	440	> 440	480		720	720					
	> 440	500	> 480	540		820	820					
2000	380	440	380	500	2000	760	760	660	200	240	8...16	140
	> 440	500	> 500	540		820	820					
	> 500	560	> 540	610		920	920					
	> 560	600	> 610	640		960	960					

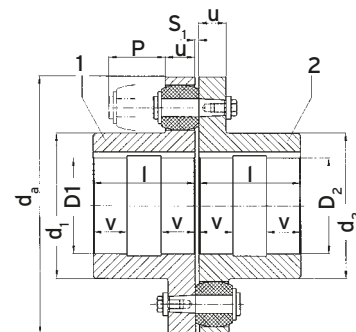

> Size
560-2000

- 1) Drill holes H7 with keyway in accordance with DIN 6885/1; tolerance zone JS9 and set screws on the keyway
- 2) Torques for shaft fit with keyway
- 3) The details of weight and moments of inertia apply for medium holes D_1 , D_2 .

SIZE 560 TO 2000

Size	Nominal torque ²⁾ WN / WS T_{KN} Nm	Max. rotation speed		Moments of inertia ³⁾		Weight ³⁾	
		WN	WS	WN 1/2 kgm ²	WS 1/2 kgm ²	WN 1/2 kg	WS 1/2 kg
560	39 000	1200	2000	4.6	4.8	145	150
				5	5.2	155	155
				5.1	5.4	150	155
630	52 000	1050	1800	7.2	7.6	180	190
				7.7	8	195	195
				8.4	8.8	210	210
710	8 000	950	1600	13	14.3	265	275
				14	14.7	270	275
				15	16	285	295
800	110 000	850	1400	22	23.3	350	370
				23	23.5	360	370
				24.5	26	380	400
900	150 000	750	1250		40		480
				39	41	500	480
				41	44	500	520
1000	195 000	680	1100	43	45	530	530
					63		620
				60	64	640	620
1120	270 000	600	1000	63	68	650	670
				68	71	680	700
				98	105	750	820
1250	345 000	550	900	100	106	780	830
				105	110	830	910
				110	120	880	950
1400	530 000	490	800	150	169	950	1050
				155	172	980	1100
				165	180	1050	1150
1600	750 000	430	700	175	190	1150	1250
				290	318	1450	1600
				300	323	1500	1600
1800	975 000	380	600	310	340	1600	1750
				330	360	1700	1850
				490	550	1950	2250
2000	1300 000	340	550	500	560	2000	2250
				530	600	2150	2400
				550	620	2200	2450
				850	1050	2850	3300
				930	1075	2900	3300
				980	1130	3100	3500
				1050	1150	3200	3600
				1350	1640	3500	4300
				1400	1670	3600	4300
				1500	1750	3800	4600
				1550	1800	3900	4600

- 1) Drill holes H7 with keyway in accordance with DIN 6885/1; tolerance zone JS9 and set screws on the keyway
- 2) Torques for shaft fit with keyway
- 3) The details of weight and moments of inertia apply for medium holes D_1 , D_2 .

DESIGNS

SIZE 105 TO 360



➤ Arrangement of the bolts and buffers on one site

SIZE 400 TO 2000



➤ Arrangement of the bolts and buffers on alternating sites

BOLTS AND BUFFERS

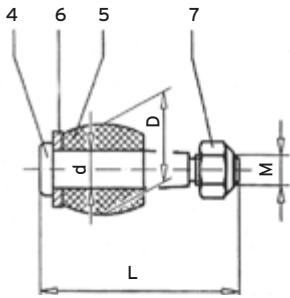

> 105-400

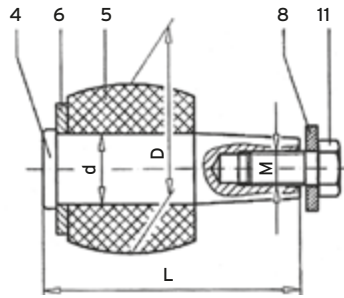

> 450-630

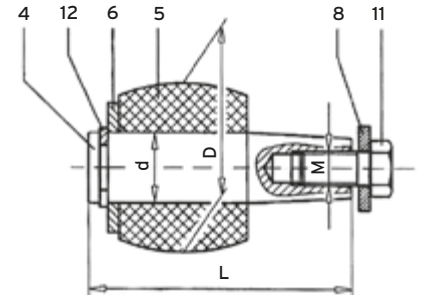

> 710-2000

Coupling size	Number per set	D mm	d mm	L mm	M mm
105	8	20	8	45	M6
125	8	24	10	53.5	M8
144	10	24	10	53.5	M8
162	9	30	12	64.5	M10
178	10	30	12	64.5	M10
198	12	30	12	64.5	M10
228	11	40	16	79	M12
252	12	40	16	79	M12
285	11	48	20	98	M16
320	12	48	20	98	M16
360	10	64	25	123	M18
400	14	64	25	123	M18
450	12	78	32	123	M16
500	14	78	32	123	M16
560	12	101	42	158	M20
630	14	101	42	158	M20
710	14	120	50	185.5	M24
800	16	120	50	185.5	M24
900	16	136	55	207.5	M24
1000	18	136	55	207.5	M24
1120	18	155	60	232.5	M30
1250	20	155	60	232.5	M30
1400	20	175	70	274	M30
1600	24	175	70	274	M30
1800	22	200	80	327	M36
2000	26	200	80	327	M36

ALIGNMENT

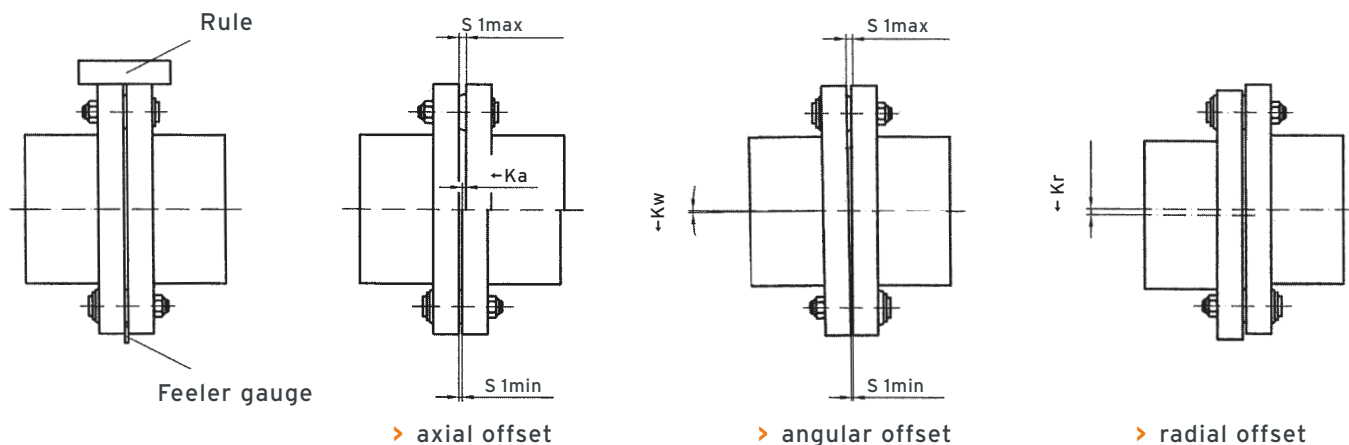

Offset of coupling parts in relation to one another may arise from an imprecise alignment during assembly, but also from operation of the machine (thermal expansion, shaft sag, excessively soft machine frame etc.).

Orpex® couplings absorb position deviations in the machines to be connected. When alignment is being performed the radial and angular offset of the shaft ends must be kept as small as possible, since this will lengthen the service life of the buffers under otherwise identical operating conditions. The coupling must be assembled and aligned in accordance with our operating instructions. The offset figures given as allowable in the table are intended for general guidance.

PERMITTED SHAFT MISALIGNMENT

The permitted shaft misalignment depends on the operating speed. As the speed increases, lower shaft misalignment values are permitted. The following table shows the correction factors for different speeds. The maximum speed for the respective coupling size and type must be observed!

$$\leftarrow K_{zul} = \leftarrow K_{1500} \cdot FKV$$

	Speed in rpm			
	500	1000	1500	3000
Correction factor FKV	1.60	1.20	1.0	0.70

The axial misalignment may occur dynamically at frequencies up to 10 Hz.

For fitting, a maximum gap dimension S_{max} and a minimum gap dimension S_{min} according to table page 11 is permitted.

Shaft misalignment $\leftarrow K_a$, $\leftarrow K_r$ und $\leftarrow K_w$ may occur simultaneously.

PERMITTED MISALIGNMENT

Size	Axial misalignment mm			Rotation speed n rpm	Angular and radial misalignment ¹⁾ mm		
	S_{lmin}	S_{lmax}	$\leftarrow K_a$ perm. $S_{lmax} - S_{lmin}$		$\leftarrow K_r$ perm.	$\leftarrow K_w$ $S_{lmax} - S_{lmin}$	$\leftarrow K_w$ perm. degree
105	2	4	2	1500	0.276		0.150
125	2	4	2		0.273		0.125
144	2	4	2		0.315		0.125
162	2	5	3		0.284		0.100
178	2	5	3		0.312		0.100
198	2	5	3		0.26		0.075
228	2	5	3		0.299		0.075
252	2	5	3		0.221		0.050
285	3	6	3		0.249		0.050
320	3	6	3		0.28		0.050
360	3	6	3		0.315		0.050
400	3	6	3		750	0.525	
450	4	7	3	0.591			0.075
500	4	7	3	0.438			0.050
560	4	8	4	0.49			0.050
630	4	8	4	0.55			0.050
710	5	9	4	0.62			0.050
800	5	9	4	1.05			0.075
900	5	10	5	1.18			0.075
1000	5	10	5	380	0.875		0.050
1120	6	11	5		0.98		0.050
1250	6	11	5		1.09		0.050
1400	6	12	6	180	2.45		0.100
1600	6	12	6		2.1		0.075
1800	8	16	8		2.4		0.076
2000	8	16	8		2.6		0.074

1) The permitted angular and radial misalignment may be used singly, if they occur simultaneously only proportionally.

Tecnamic GmbH & Co. KG

Kleinbahnstraße 21
59759 Arnsberg
Germany

T +49 2932 300-440

F +49 2932 300-830

E info@tecnamic.com



TECNAMIC

www.tecnamic.com

