

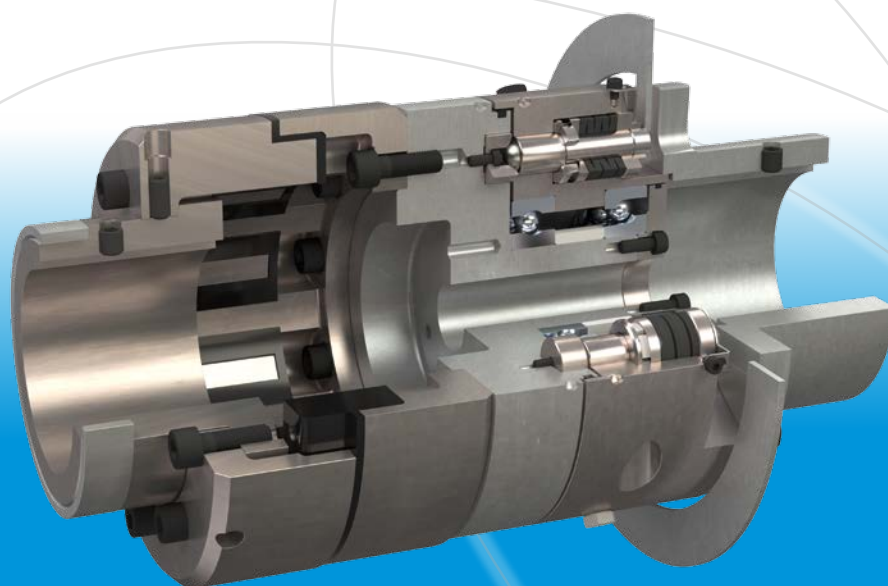

*your reliable partner*



## **EAS<sup>®</sup>-dutytorque**

K.4043.V04.EN

[www.mayr.com](http://www.mayr.com)

# We safeguard the movements of this world



## Specialists for power transmission for more than a century

*mayr*® power transmission is one of the most traditional and yet most innovative German companies in the field of power transmission. From modest beginnings in the year 1897, the family enterprise from the Allgäu region has developed into world market leader. Today, 600 employees work at the headquarters in Mauerstetten; more than 1000 employees work for the company worldwide.

## Unsurpassed - our standard range

*mayr*® power transmission offers an extensive variety of torque limiters, safety brakes, backlash-free shaft misalignment compensation couplings and high-quality DC drives. Also when it comes to customer-specific requirements, the company possesses the expertise to develop customized and economical solutions. This is why numerous renowned machine manufacturers trust in holistic solutions by *mayr*® power transmission.

## Available worldwide

With eight subsidiaries in Germany, sales offices in the USA, France, Great Britain, Italy, Singapore and Switzerland as well as 36 additional country representatives, *mayr*® is available in all important industrial areas, guaranteeing optimum customer service around the globe.

## Tested quality and reliability

*mayr*® products are subject to meticulous quality inspections. These include quality assurance measures during the construction process as well as a comprehensive final inspection. Only the best, tested quality leaves our factory. All products are rigorously tested on calibrated test stands, and adjusted precisely to the requested values. An electronic database in which the measurement values are archived together with the associated serial numbers guarantees 100 % traceability. On request, we confirm the product characteristics with a test protocol.

The certification of our quality management according to DIN EN ISO 9001:2008 confirms the quality-consciousness of our colleagues at every level of the company.

## Never compromise on safety

We make no compromises where safety is concerned. Only top products of a perfect quality guarantee that no people are injured or machines damaged in case of malfunctions, collisions and other hazardous situations. The safety of your employees and machines is our motivation to always provide the best and most reliable clutches, couplings or brakes.

*mayr*® power transmission holds numerous ground-breaking patents, and is the global market or technological leader for

- application-optimised **safety brakes**
- torque limiting **safety clutches** and
- backlash-free **servo couplings**.

## EAS<sup>®</sup>-dutytorque

### Perfect protection for your extruder

#### The outstanding characteristics of the EAS<sup>®</sup>-dutytorque

- Fast separation of input and output on overload
- High reliability due to robust mechanics
- High switch-off and repetitive accuracy
- Simple and fast re-engagement
- Can be disassembled radially without moving the motor
- High balance quality
- Extensive adjustable torque ranges
- Large shaft bores
- Long service lifetime
- Separable shaft coupling
- Minimum maintenance requirements
- Compact design



The EAS<sup>®</sup>-dutytorque clutches Types 4043.5\_400, 4043.6\_400 and 4043.7\_400 are also available in ATEX design according to the directive 2014/34/EU.

#### Function

In malfunction-free operation, the EAS<sup>®</sup>-dutytorque transmits the torque with high precision and compensates for shaft misalignments between the input and the output. If the set torque is exceeded due to malfunction or blockage, the clutch disengages reliably within a fraction of a second and separates the input and the output almost residual torque-free. The clutch remains disengaged until it is re-engaged by hand.

#### Torque Path

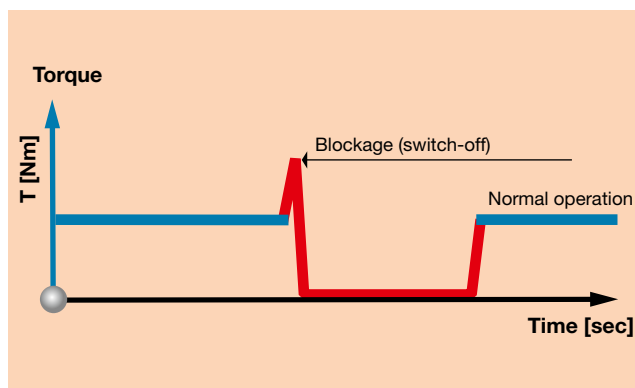

#### Why you should use the new EAS<sup>®</sup>-dutytorque:

- Your extruders are protected from damage in case of malfunctions.
- You save repair costs and downtimes.
- Input and output can be separated easily on the clutch.
- Due to the large max. bores, you have free choice when selecting motors.
- The high balance quality guarantees smooth running on the drive.
- You have to invest comparatively little money in order to protect your valuable machine components from overload damage.

#### Split hub of the flexible coupling

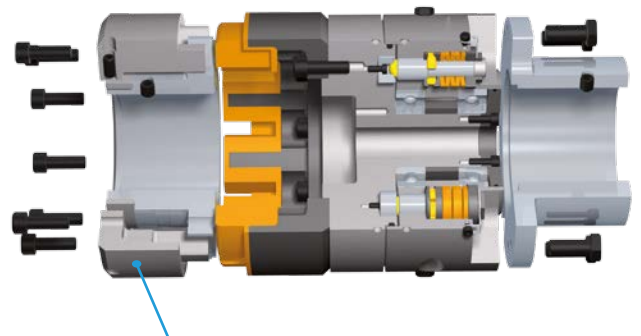

The **pushed back claw ring of the flexible coupling** allows separation of the input and output without moving the input and output axially.

#### Radial Disassembly

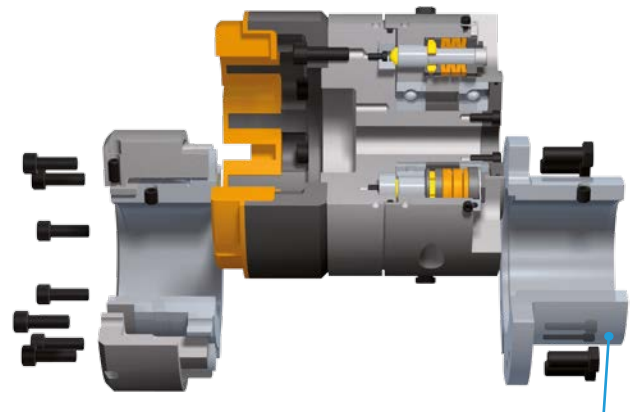

Once the claw ring is pushed back and the **EAS<sup>®</sup>-element clutch hub** is unscrewed, the coupling can be removed radially without moving the input and output axially.

## EAS®-dutytorque

### Overload module with flexible shaft coupling and hub

Type 4043\_0400

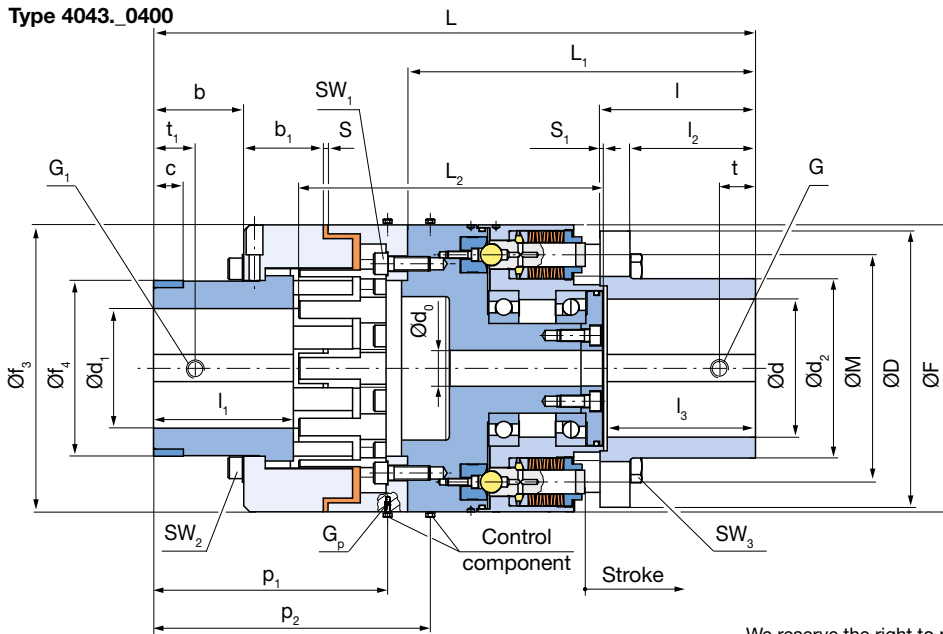

Type 4043\_1400

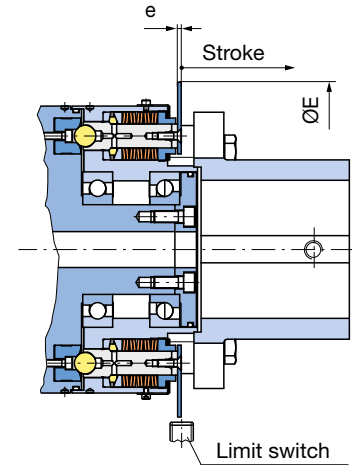

We reserve the right to make dimensional and constructional alterations.

Dimensions [mm]	Size								
	2	3	4	5	6	7	8	9	
b	43	45	45	75,5	57	96	101,5	117	
b <sub>1</sub>	57	62,5	62,5	66,5	76	80	86,5	94	
c	20	20	20	25	20	35	30	40	
Ø D	185	185	240	240	240	310	310	310	
Ø d <sub>0</sub>	30,5	30,5	35	35	35	35	35	35	
Ø d <sub>2</sub>	125	125	165	165	165	190	190	190	
Ø E	250	250	280	280	280	400	400	400	
e	3	3	3	3	3	3	3	3	
Ø F	190	190	240	240	240	330	330	330	
Ø f <sub>3</sub>	194	214	214	240	265	295	330	370	
Ø f <sub>4</sub> <sup>1)</sup>	122	136	136	147	165	182	209	242	
G <sup>2)</sup>	M8 / M10	M8 / M10	M12	M12	M12	M16	M16	M16	
G <sub>1</sub>	M10	M12	M12	M16	M16	M16	M16	M16	
G <sub>p</sub>	M8	M8	M8	M8	M8	M12	M12	M12	
L	368	381,5	472	510,5	512,5	636	654,5	685	
L <sub>1</sub>	207,5	207,5	298	298	298	372	372	372	
L <sub>2</sub>	202	210	255,5	262	275	326,5	335,5	345,5	
l	85	85	130	130	130	160	160	160	
l <sub>1</sub>	78	82,5	82,5	115,5	103,5	144	154	173	
l <sub>2</sub>	70	70	105	105	105	135	135	135	
l <sub>3</sub>	80	80	124	124	124	154	154	154	
Ø M	140	140	190	190	190	260	260	260	
p <sub>1</sub>	188,5	202	221	259,5	261,5	318	336,5	367	
p <sub>2</sub>	231	244,5	263	301,5	303,5	370	388,5	419	
S	3,5	4,0	4,0	4,0	5,5	8,0	8,0	8,0	
S <sub>1</sub>	3	3	3	3	3	3	3	3	
t	30	30	30	30	30	30	30	30	
t <sub>1</sub>	30	30	30	35	36	50	50	60	

Bores [mm]		Size								
		2	3	4	5	6	7	8	9	
EAS®-hub side	d <sub>max</sub>	90	90	120	120	120	140	140	140	
Flexible side	d <sub>1max</sub>	85	95	95	100	115	130	135	160	

1) Ring outer diameter: tolerance e8.

2) Dependent on diameters d or d<sub>1</sub>.

3) The values refer to 1.500 rpm.

4) Mass moment of inertia and weights refer to medium bores.

5) See Technical Data, page 5: limit torques for overload M<sub>G</sub>.

## EAS®-dutytorque

Technical Data				Size								
				2	3	4	5	6	7	8	9	
Limit torques for overload	Type 4043.3_400 (Torque range 3)	$M_{G\ min}$	[Nm]	70	70	150	150	150	800	800	800	
		$M_{G\ max}$	[Nm]	140	140	400	400	400	2000	2000	2000	
	Type 4043.4_400 (Torque range 4)	$M_{G\ min}$	[Nm]	140	140	350	350	350	2000	2000	2000	
		$M_{G\ max}$	[Nm]	280	280	900	900	900	4000	4000	4000	
	Type 4043.5_400 (Torque range 5)	$M_{G\ min}$	[Nm]	170	170	700	700	700	3000	3000	3000	
		$M_{G\ max}$	[Nm]	350	350	1400	1400	1400	6000	6000	6000	
	Type 4043.6_400 (Torque range 6)	$M_{G\ min}$	[Nm]	350	350	1400	1400	1400	6000	6000	6000	
		$M_{G\ max}$	[Nm]	700	700	2800	2800	2800	9000	12000	12000	
	Type 4043.7_400 (Torque range 7)	$M_{G\ min}$	[Nm]	700	700	-	2000	2800	-	-	8500	
		$M_{G\ max}$	[Nm]	1400	1400	-	4000	5600	-	-	17000	
EAS®-element	Size			01	01	0	0	0	1	1	1	
	Number	Torque ranges 3 to 6		2	2	2	2	2	3	3	3	
Torque range 7			4	4	-	2	4	-	-	3		
Maximum speed	$n_{max}$	[rpm]	3500	3000	3000	2750	2500	2250	2000	1750		
Bolt stroke on overload		[mm]	4	4	6	6	6	8	8	8		
Flexible shaft coupling Type 4043.__400	Nominal torque	$T_{KN}$	[Nm]	1650	2400	2400	3700	5800	7550	9900	14000	
	Peak torque	$T_{KS}$	[Nm]	2400	4200	4200	6200	8300	10500	14500	20000	
	Permitted shaft misalignments <sup>3)</sup>	axial	$\Delta K_a$	[mm]	± 1,5	± 2,0	± 2,0	± 2,0	± 2,5	± 2,5	± 2,5	± 2,5
		radial	$\Delta K_r$	[mm]	0,3	0,3	0,3	0,3	0,3	0,3	0,3	0,3
	angular	$\Delta K_w$	[mm]	0,3	0,3	0,3	0,3	0,3	0,3	0,3	0,3	

Mass Moments of Inertia and Weights				Size							
				2	3	4	5	6	7	8	9
Mass moments of inertia <sup>4)</sup>	EAS®-hub side	J	[kgm <sup>2</sup> ]	0,088	0,088	0,318	0,318	0,318	1,244	1,244	1,244
	Flexible side	J	[kgm <sup>2</sup> ]	0,136	0,192	0,319	0,416	0,587	1,499	1,967	2,756
Weights <sup>4)</sup>			[kg]	47,5	52,2	90,3	98	108,9	213,5	238,2	265,3

Screws Type 4043.__400				Size							
				2	3	4	5	6	7	8	9
In claw ring and cam ring	Number			9xM10	9xM12	9xM12	10xM12	10xM14	10xM14	10xM16	11xM16
	Wrench opening	SW <sub>1</sub> /SW <sub>2</sub>	[mm]	8	10	10	10	12	12	14	14
	Tightening torque		[Nm]	71	143	143	143	220	220	350	350
In the hub, overload-side	Number			8xM12	8xM12	8xM16	8xM16	8xM16	9xM20	9xM20	9xM20
	Wrench opening	SW <sub>3</sub>	[mm]	19	19	24	24	24	30	30	30
	Tightening torque		[Nm]	122	122	300	300	300	590	590	590

## Order Number

### Design

3 Overload module with flexible shaft coupling and hub



__	/	4	0	4	3	.	__	__	4	0	0	/	__	/	__
▲							▲	▲	▲				▲		▲
Sizes		Torque range <sup>5)</sup>					Switching disk		Claw ring			Bore		Bore	
2 to 9		Torque range 3 Torque range 4 Torque range 5 Torque range 6 Torque range 7					0 without 1 with		0 moveable / clampable			Ø d <sup>H7</sup>		Ø d <sub>1</sub> <sup>H7</sup>	

Example: 4 / 4043.61400 / 100 / 90

## Technical Explanations

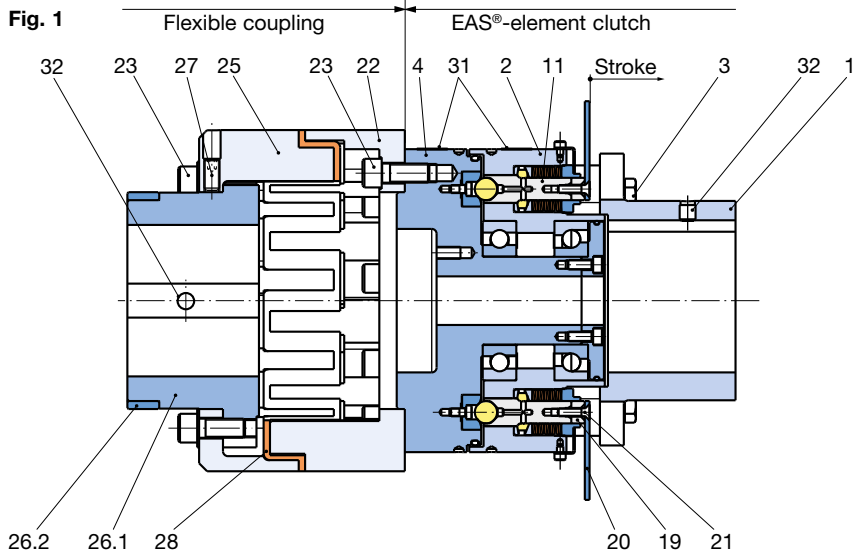

### Parts List

1	Hub
2	Element flange
3	Hexagon head screw
4	Pressure flange
11	Overload element
19	Distance bushing
20	Switching disk (Type 4043...1400)
21	Countersunk screw
22	Cam ring
23	Cap screw
25	Claw ring
26.1	Flange hub
26.2	Centring ring
27	Set screw
28	Flexible intermediate ring
31	Guideline sign for re-engagement position
32	Set screw

### Design

The EAS®-dutytorque clutches are mechanically disengaging overload clutches (EAS®-element clutches) with a mounted, plug-in elastomer compensation coupling (flexible coupling).

The elastomer compensation coupling compensates for misalignments of the shaft ends (for the maximum permitted shaft misalignments, see Technical Data, page 5) and consists of the following components: Flange hub (26.1), claw ring (25), flexible intermediate ring (28), cam ring (22) and the cap screws (23).

At the flange hub (26.1) end, there is a centring ring (26.2), which is intended for holding the claw ring (25) in disassembled state.

Disassembly of the claw ring (25) is necessary when:

- the flexible intermediate ring (28) of the coupling has to be replaced, or
- the running characteristics of the motor in dry running have to be checked; the input and the output can be separated without moving the motor (see 'Radial Disassembly').

In the element flange (2), there are 2 cone lubricating nipples for greasing the bearing and 2 to 4 cone lubricating nipples (dependent on the Size and the Type) for greasing the overload elements (11).

### Function

When the set limit torque is exceeded (overload), the clutch disengages. The bolts (11.1.1, Fig. 3) in the overload elements (11) carry out an axial movement (stroke) and remain disengaged.

In disengaged state, the clutch slows down freely without any residual torque.

The drive can be switched off electrically via:

- a limit switch (only for design with switching disk (20); the switching disk stroke can be used for overload identification via a limit switch), or
- a speed monitoring: for this there are 2 hexagon head screws (control components, see Fig. on page 4). They can either be screwed into the pressure flange (4) or in the element flange (2).

### Torque Adjustment

The limit torque  $M_G$  for overload is set by changing the cup spring pre-tension (11.8, Fig. 2) on each overload element (11).

For this, dimension "a" is determined using the Adjustment Diagram included in clutch delivery. Dimension "a" is the distance between the hub (1, Fig. 2) and the facing side of the adjusting nut (11.4, Fig. 2). The adjusting nut (11.4) in the overload element (11) is turned to this dimension "a" using an open-ended wrench.

### Radial Disassembly

For a detailed installation description, please see the Installation and Operational Instructions corresponding to the product.

- 1) Remove the cap screws (23) in the claw ring (25).
- 2) Pull the claw ring (25) back to the flange hub (26.1) end until reaching the centring (centring ring 26.2).
- 3) Tighten the 3 set screws (27).
- 4) Remove the hexagon head screws (3) in the element flange (2).
- 5) Lift the remaining clutch part (element flange (2), pressure flange (4) and cam ring (22)) radially between the input and the output shafts.
- 6) The motor can be checked via short-term acceleration or the intermediate ring (28) can be removed axially.

### Re-engagement

The marking bores on the outer diameter of the element flange (2) and the pressure flange (4) must align.

Re-engagement is carried out simple by placing axial pressure on the bolt ends of each overload element. Depending on the means available, the accessibility of the installation space etc., re-engagement can be carried out in different ways:

- manually, using a suitable tool (Fig. 3)
- by tapping with a plastic hammer

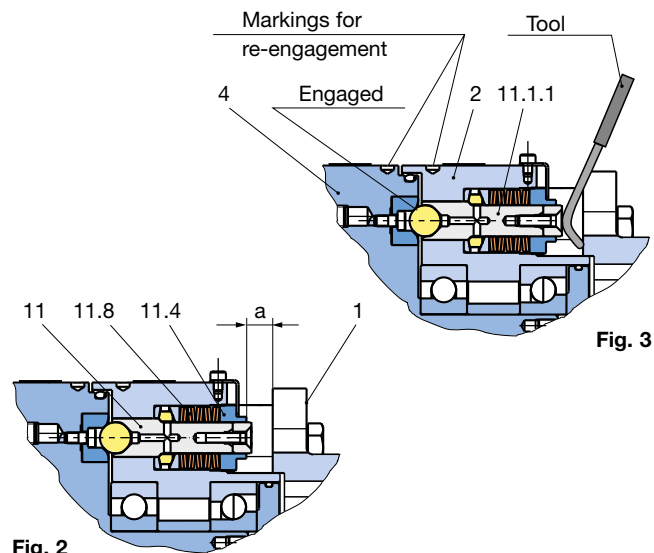

## Product Summary

### Safety Clutches/Overload Clutches

- **EAS®-Compact®/EAS®-NC**  
Positive locking and completely backlash-free torque limiting clutches
- **EAS®-smartic®**  
Cost-effective torque limiting clutches, quick installation
- **EAS®-element clutch/EAS®-elements**  
Load-disconnecting protection against high torques
- **EAS®-axial**  
Exact limitation of tensile and compressive forces
- **EAS®-Sp/EAS®-Sm/EAS®-Zr**  
Load-disconnecting torque limiting clutches with switching function
- **ROBA®-slip hub**  
Load-holding, frictionally locked torque limiting clutches
- **ROBA®-contitorque**  
Magnetic continuous slip clutches
- **EAS®-HSC/EAS®-HSE**  
High-speed safety clutches for high-speed applications



### Shaft Couplings

- **smartflex®/primeflex®**  
Perfect precision couplings for servo and stepping motors
- **ROBA®-ES**  
Backlash-free and damping for vibration-sensitive drives
- **ROBA®-DS/ROBA®-D**  
Backlash-free, torsionally rigid all-steel couplings
- **ROBA®-DSM**  
Cost-effective torque-measuring couplings



### Electromagnetic Brakes/Clutches

- **ROBA-stop® standard**  
Multifunctional all-round safety brakes
- **ROBA-stop®-M motor brakes**  
Robust, cost-effective motor brakes
- **ROBA-stop®-S**  
Water-proof, robust monoblock brakes
- **ROBA®-duplostop®/ROBA®-twinstop®/ROBA-stop®-silenzio®**  
Doubly safe elevator brakes
- **ROBA®-diskstop®**  
Compact, very quiet disk brakes
- **ROBA®-topstop®**  
Brake systems for gravity loaded axes
- **ROBA®-linearstop**  
Backlash-free brake systems for linear motor axes
- **ROBA®-guidestop**  
Backlash-free holding brake for profield rail guides
- **ROBATIC®/ROBA®-quick/ROBA®-takt**  
Electromagnetic clutches and brakes, clutch brake units



### DC Drives

- **tendo®-PM**  
Permanent magnet-excited DC motors

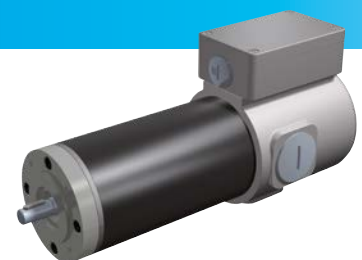

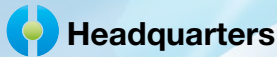

## Headquarters

**Chr. Mayr GmbH + Co. KG**  
**Eichenstraße 1, D-87665 Mauerstetten**  
**Tel.: +49 83 41/8 04-0, Fax: +49 83 41/80 44 21**  
**www.mayr.com, E-Mail: info@mayr.com**



*your reliable partner*

## Service Germany

### Baden-Württemberg

Esslinger Straße 7  
 70771 Leinfelden-Echterdingen  
 Tel.: 07 11/45 96 01 0  
 Fax: 07 11/45 96 01 10

### Bavaria

Industriestraße 51  
 82194 Gröbenzell  
 Tel.: 0 81 42/50 19 80-7

### Chemnitz

Bornaer Straße 205  
 09114 Chemnitz  
 Tel.: 03 71/4 74 18 96  
 Fax: 03 71/4 74 18 95

### Franken

Unterer Markt 9  
 91217 Hersbruck  
 Tel.: 0 91 51/81 48 64  
 Fax: 0 91 51/81 62 45

### Kamen

Herbert-Wehner-Straße 2  
 59174 Kamen  
 Tel.: 0 23 07/24 26 79  
 Fax: 0 23 07/24 26 74

### North

Schiefer Brink 8  
 32699 Extertal  
 Tel.: 0 57 54/9 20 77  
 Fax: 0 57 54/9 20 78

## Branch office

### China

Mayr Zhangjiagang  
 Power Transmission Co., Ltd.  
 Fuxin Road No.7, Yangshe Town  
 215637 Zhangjiagang  
 Tel.: 05 12/58 91-75 67  
 Fax: 05 12/58 91-75 66  
 info@mayr-ptc.cn

### Great Britain

Mayr Transmissions Ltd.  
 Valley Road, Business Park  
 Keighley, BD21 4LZ  
 West Yorkshire  
 Tel.: 0 15 35/66 39 00  
 Fax: 0 15 35/66 32 61  
 sales@mayr.co.uk

### France

Mayr France S.A.S.  
 Z.A.L. du Minopole  
 Rue Nungesser et Coli  
 62160 Bully-Les-Mines  
 Tel.: 03.21.72.91.91  
 Fax: 03.21.29.71.77  
 contact@mayr.fr

### Italy

Mayr Italia S.r.l.  
 Viale Veneto, 3  
 35020 Saonara (PD)  
 Tel.: 0498/79 10 20  
 Fax: 0498/79 10 22  
 info@mayr-italia.it

### Singapore

Mayr Transmission (S) PTE Ltd.  
 No. 8 Boon Lay Way Unit 03-06,  
 TradeHub 21  
 Singapore 609964  
 Tel.: 00 65/65 60 12 30  
 Fax: 00 65/65 60 10 00  
 info@mayr.com.sg

### Switzerland

Mayr Kupplungen AG  
 Tobelackerstraße 11  
 8212 Neuhausen am Rheinfall  
 Tel.: 0 52/6 74 08 70  
 Fax: 0 52/6 74 08 75  
 info@mayr.ch

### USA

Mayr Corporation  
 10 Industrial Avenue  
 Mahwah  
 NJ 07430  
 Tel.: 2 01/4 45-72 10  
 Fax: 2 01/4 45-80 19  
 info@mayrcorp.com

## Representatives

### Australia

Drive Systems Pty Ltd.  
 12 Sommersby Court  
 Lysterfield, Victoria 3156  
 Australien  
 Tel.: 0 3/97 59 71 00  
 dean.hansen@drivesystems.com.au

### India

National Engineering  
 Company (NENCO)  
 J-225, M.I.D.C.  
 Bhosari Pune 411026  
 Tel.: 0 20/27 13 00 29  
 Fax: 0 20/27 13 02 29  
 nenco@nenco.org

### Japan

MATSUI Corporation  
 2-4-7 Azabudai  
 Minato-ku  
 Tokyo 106-8641  
 Tel.: 03/35 86-41 41  
 Fax: 03/32 24 24 10  
 k.goto@matsui-corp.co.jp

### Netherlands

Groneman BV  
 Amarilstraat 11  
 7554 TV Hengelo OV  
 Tel.: 074/2 55 11 40  
 Fax: 074/2 55 11 09  
 aandrijftechnik@groneman.nl

### Poland

Wamex Sp. z o.o.  
 ul. Pozaryskiego, 28  
 04-703 Warszawa  
 Tel.: 0 22/6 15 90 80  
 Fax: 0 22/8 15 61 80  
 wamex@wamex.com.pl

### South Korea

Mayr Korea Co. Ltd.  
 15, Yeondeok-ro 9beon-gil  
 Seongsan-gu  
 51571 Changwon-si  
 Gyeongsangnam-do, Korea  
 Tel.: 0 55/2 62-40 24  
 Fax: 0 55/2 62-40 25  
 info@mayrkorea.com

### Taiwan

German Tech Auto Co., Ltd.  
 No. 28, Fenggong Zhong Road,  
 Shengang Dist.,  
 Taichung City 429, Taiwan R.O.C.  
 Tel.: 04/25 15 05 66  
 Fax: 04/25 15 24 13  
 abby@zfgta.com.tw

### Czech Republic

BMC - TECH s.r.o.  
 Hviezdoslavova 29 b  
 62700 Brno  
 Tel.: 05/45 22 60 47  
 Fax: 05/45 22 60 48  
 info@bmc-tech.cz

## More representatives:

Austria, Belgium, Brazil, Canada, Denmark, Finland, Greece, Hongkong, Hungary, Indonesia, Israel, Luxembourg, Malaysia, New Zealand, Norway, Philippines, Romania, Russia, Slovakia, Slovenia, South Africa, Spain, Sweden, Thailand, Turkey

You can find the complete address for the representative responsible for your area under [www.mayr.com](http://www.mayr.com) in the internet.

19/06/2017 GC/SC

